



INDUSTRIAL 12,13,14 OKT. 2021
BRABANTHALLEN
HEAT+POWER

Empowering Sustainability



Aardgasloze drogers

Energietransitie industrie

ir. Jan Grift rea

2050

2030





Industrie

Chemie | Procesindustrie | F&B
| Rubber & Kunststoff | Pharma |
Diervoeding | Papier & Karton



Land- en tuinbouw

Ondernemers & clusters |
Glastuinbouw Nederland |
Warmtenetten



Grootzakelijke markt

Overheid | Woningcorporaties |
Maatschappelijk vastgoed |
Commercieel vastgoed

INDUSTRIAL 12,13,14 OKT. 2021
BRABANTHALLEN
HEAT+POWER



loopbaan

- '75- HTS Zwolle – wtb-energie
- '79- UT-wtb-energie&processen
- '84- IMT
- '90- M+I
- '00- Deerns
- '06- Energy Matters ↓
- '18- **BlueTerra Energy Experts B.V.**
- '20- **ook Docent Hogeschool Rotterdam**

Rea, lid werkgroep industrie Fedec





Inhoud

- CO2-emissie drogen
- Resultaten studies
 - Petfood
 - Papierindustrie
 - Steam drying



CO2-emissie drogen

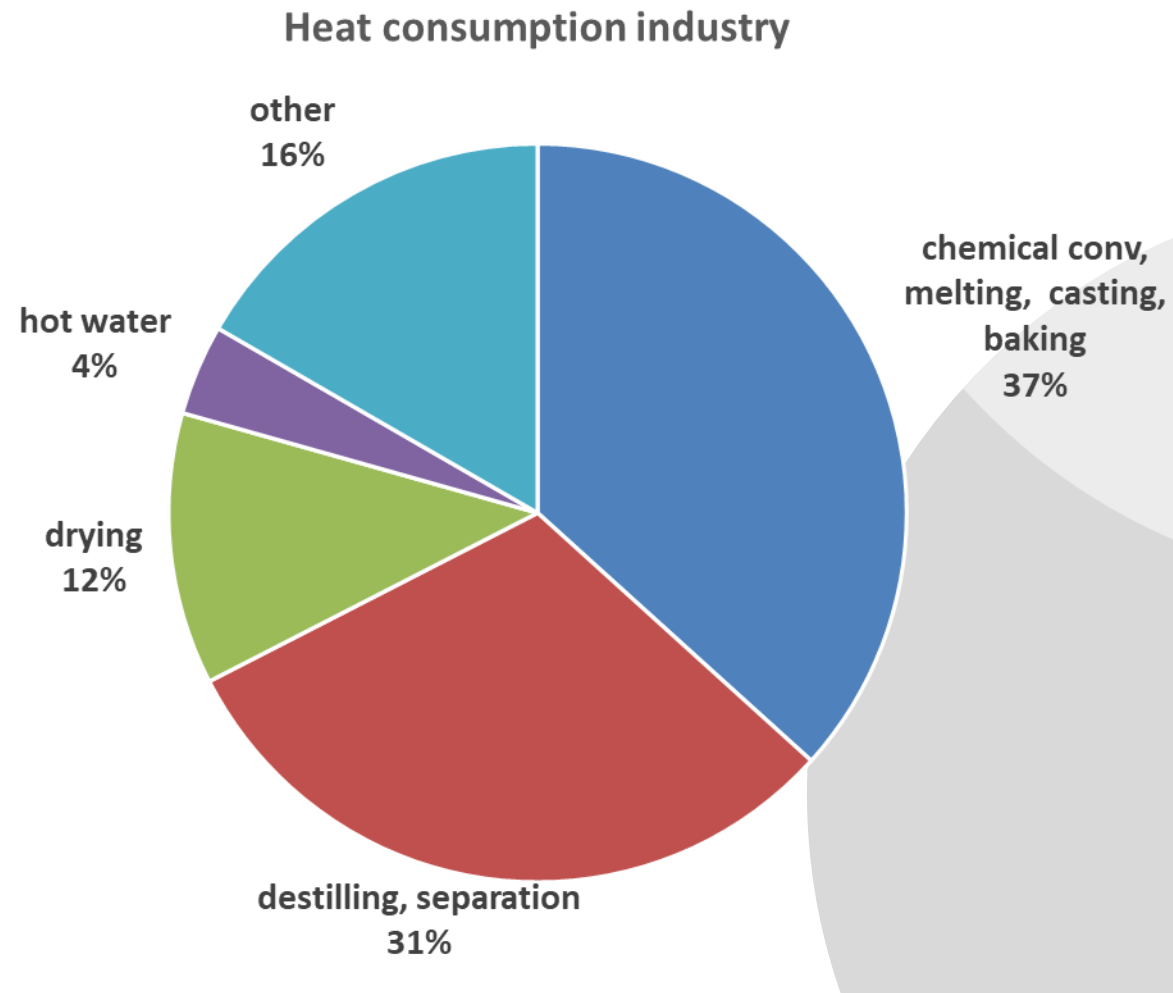



Petfood droger

Geelen Counterflow (NL; prod. 11 ton/h)





Warmtepomp geïntegreerde droger

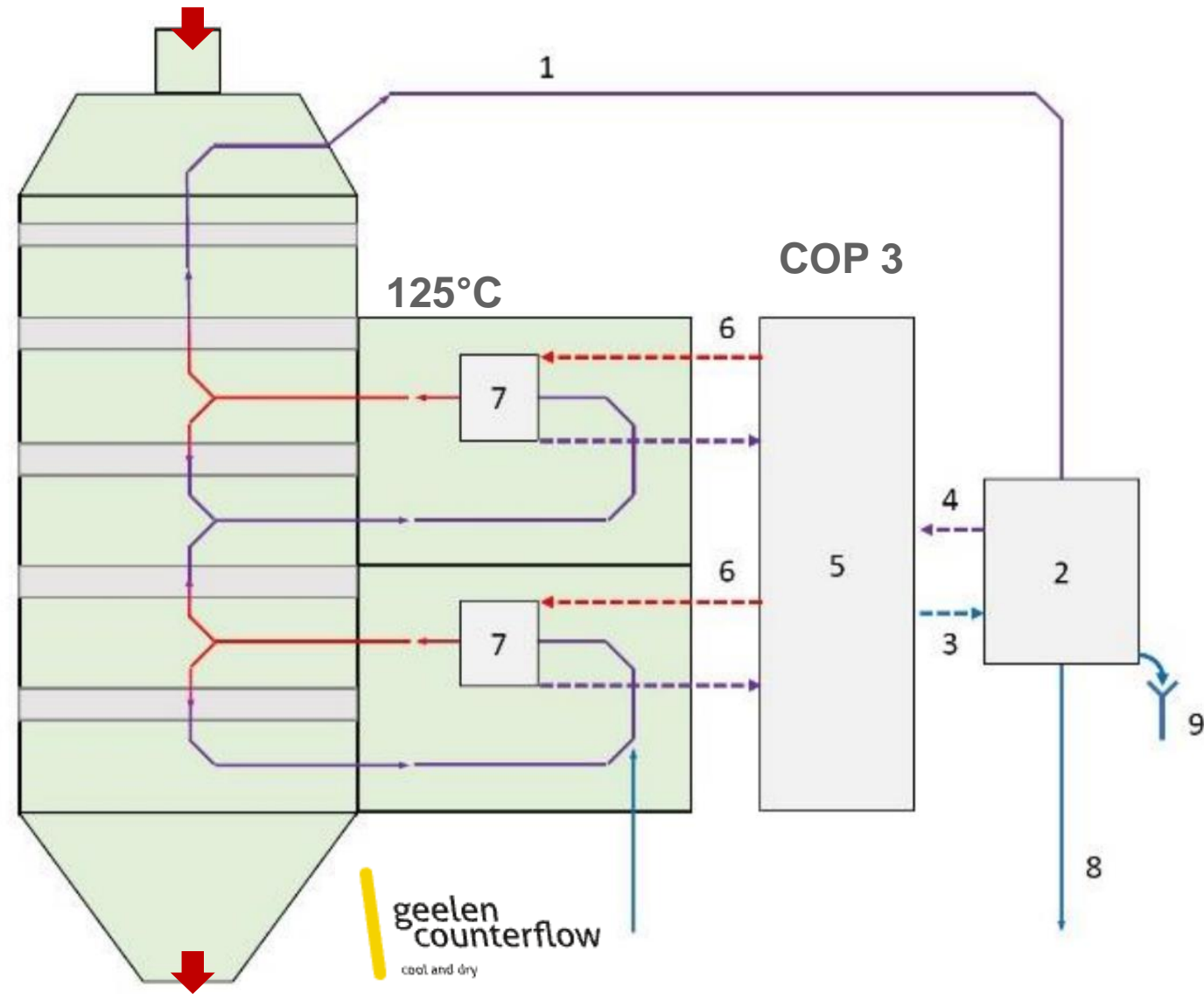



HT warmtepomp; 200°C; ca 2 MW_{th} Ochsner (O)





HT warmtepomp; 200 °C; ca 0,75 MW_{th}

Olvondo (N) SPP HighLift

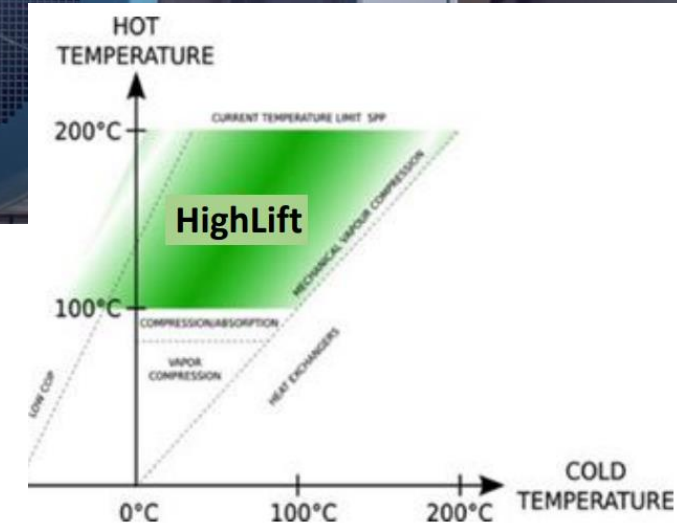
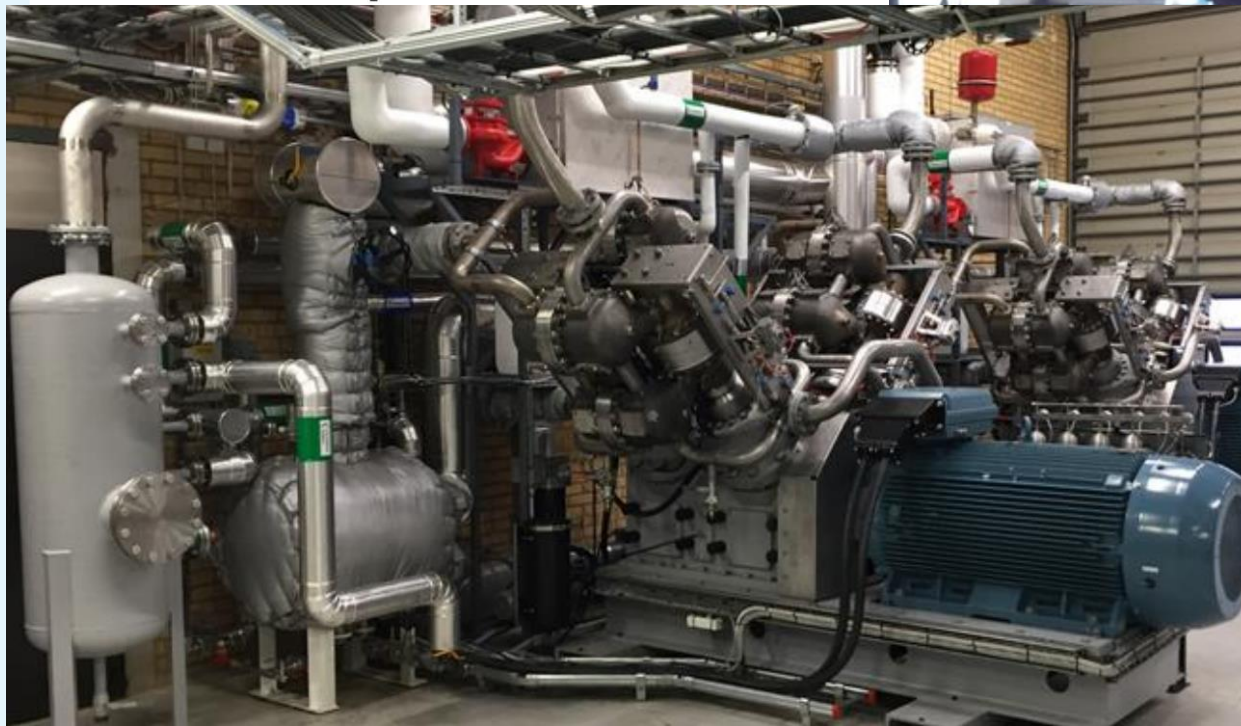
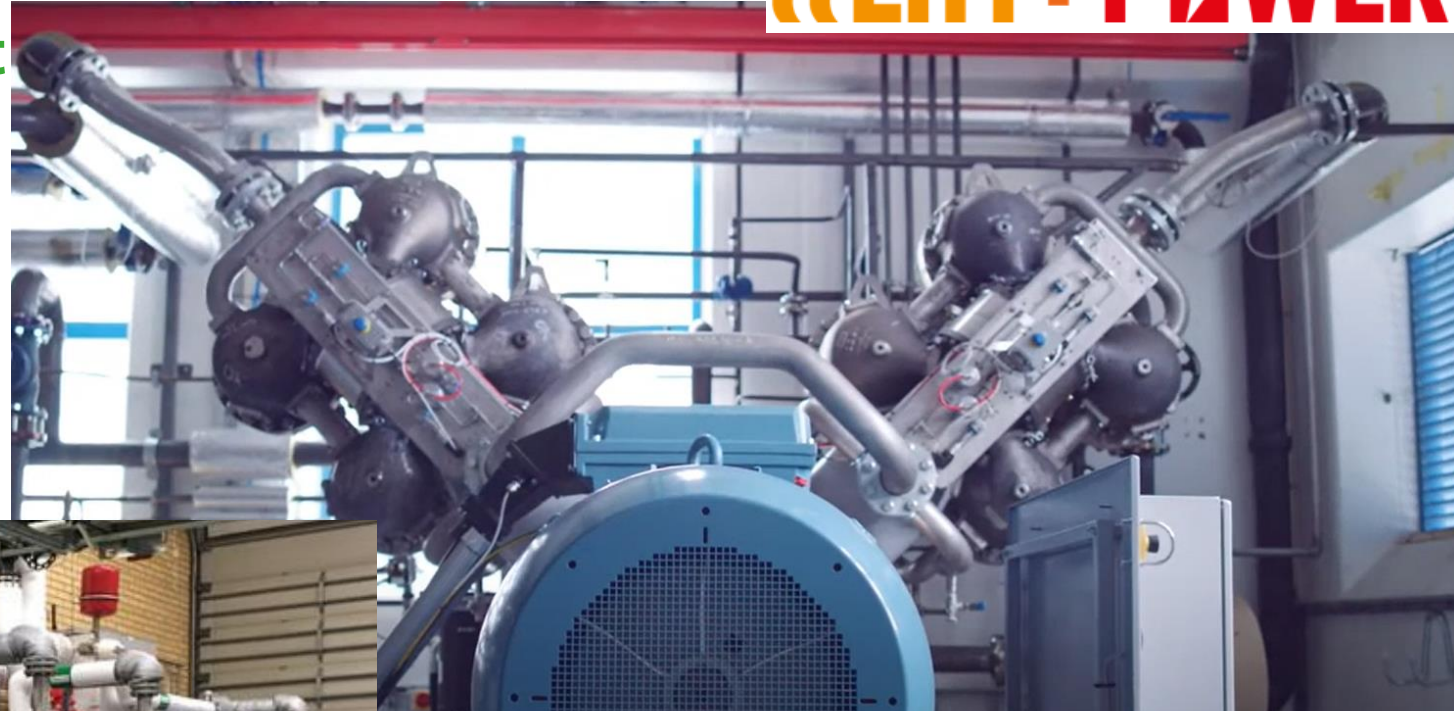
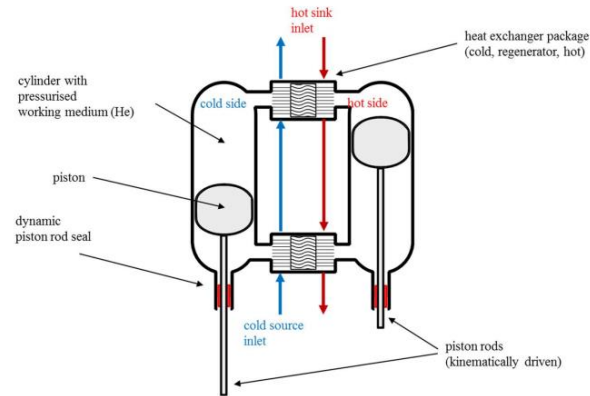



Papier industrie (studie)

Cascade warmtepomp

Casebeschrijving Papierfabriek

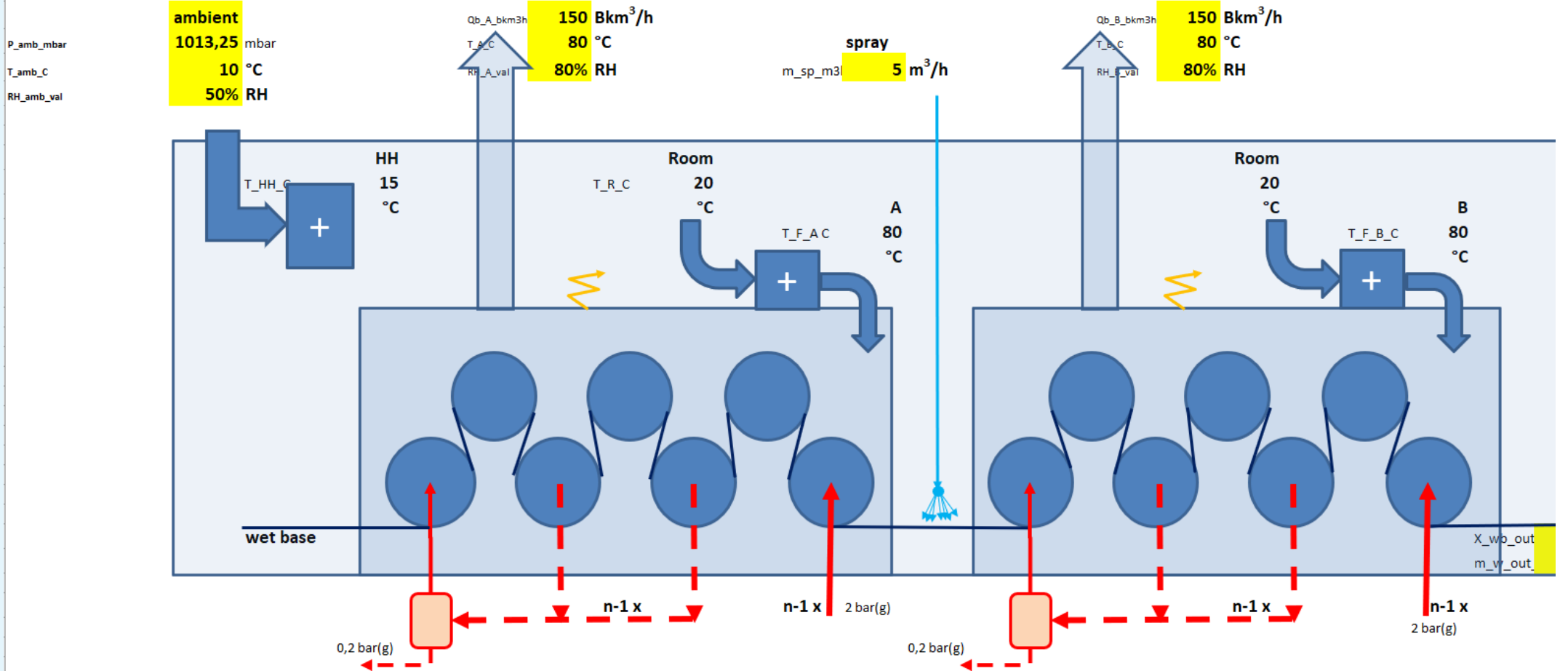



Cascade warmtepomp papierdroger

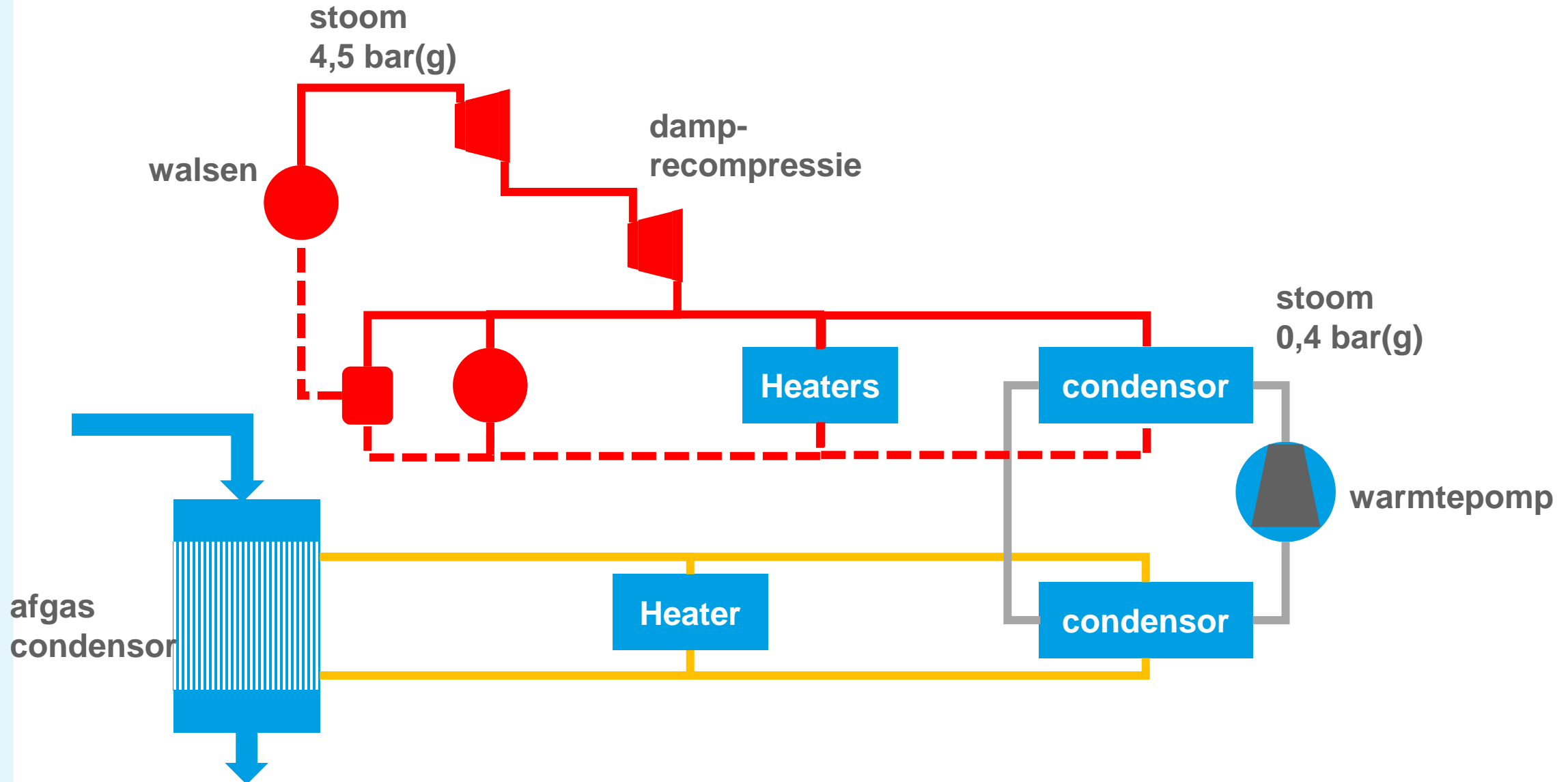



Super heated steam drying - paper pulp



Year of Manufacture: 2016
Country: Sweden
Customer: Paper Industry

Application: Steam recycling
at paper pulp
drying with
overpressure
steam dryer

Inlet Steam: 3.2 bar_a
Outlet Steam: 16 bar_a
Steam Flow Rate: 2 x 8 t/h

El. Power Demand: 2 x 1,325 kW_{el.}
Heat Load Steam_{out}: 2 x 5,600 kW_{th}

COP: ~4.2





Super heated steam protein meal dryer

0,15 t/h; 1979; 80% vocht input

SUPERHEATED STEAM DRYER WITH BACKMIXING

- 1 Generated steam
- 2 Superheater
- 3 Cyclone
- 4 Drying ducts
- 5 Dry sludge
- 6 Screw conveyor
- 7 Rotary valve
- 8 Mixer
- 9 TroMaxx rotary valve
- 10 Wet sludge
- 11 Fan

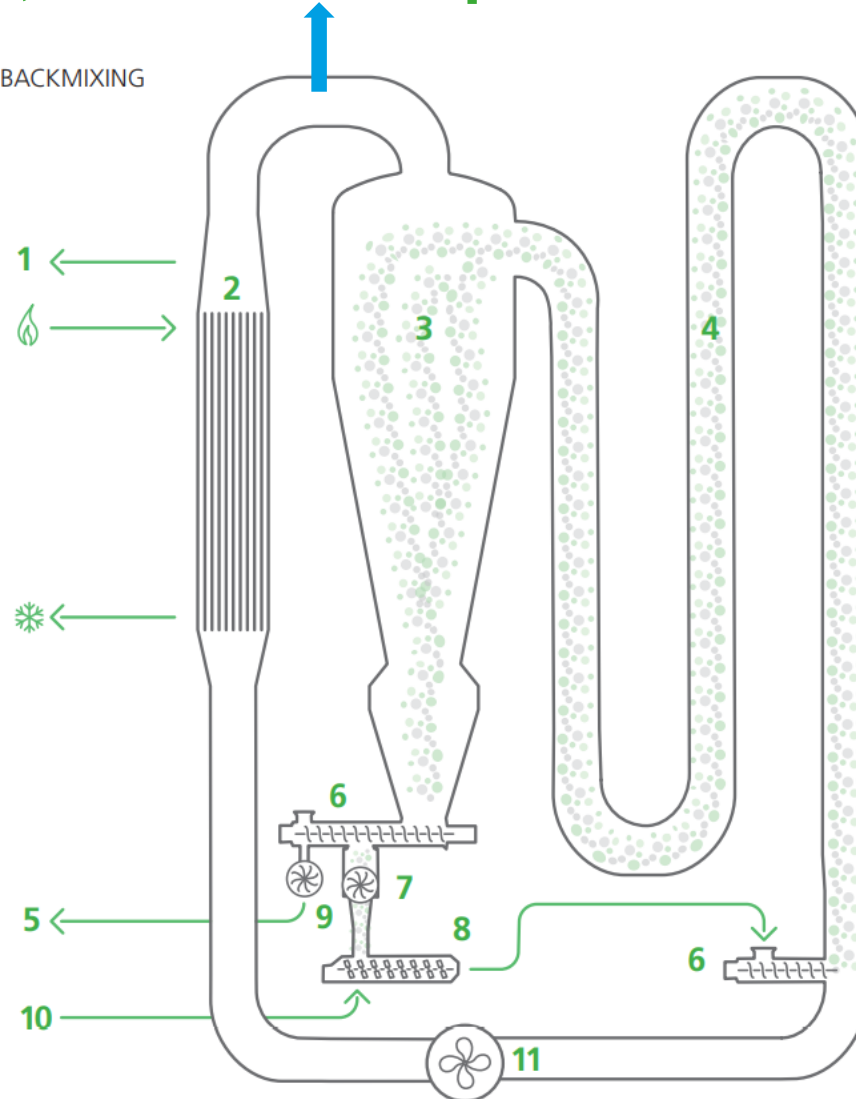

SWEDISH EXERGY AB | EXPERIENCE & KNOW-HOW FOR OPTIMAL SOLUTIONS
 Gamla Rambergsvägen 34, SE-417 01, Gothenburg, Sweden | Phone: +46 (0) 31 51 39 90, Fax: +46 (0) 31 51 79 60
 E-post: info@swedishexergy.com | www.swedishexergy.com





Superheated steam drying paper pulp

- Principle „Steam Recycling in Closed Steam Cycle“

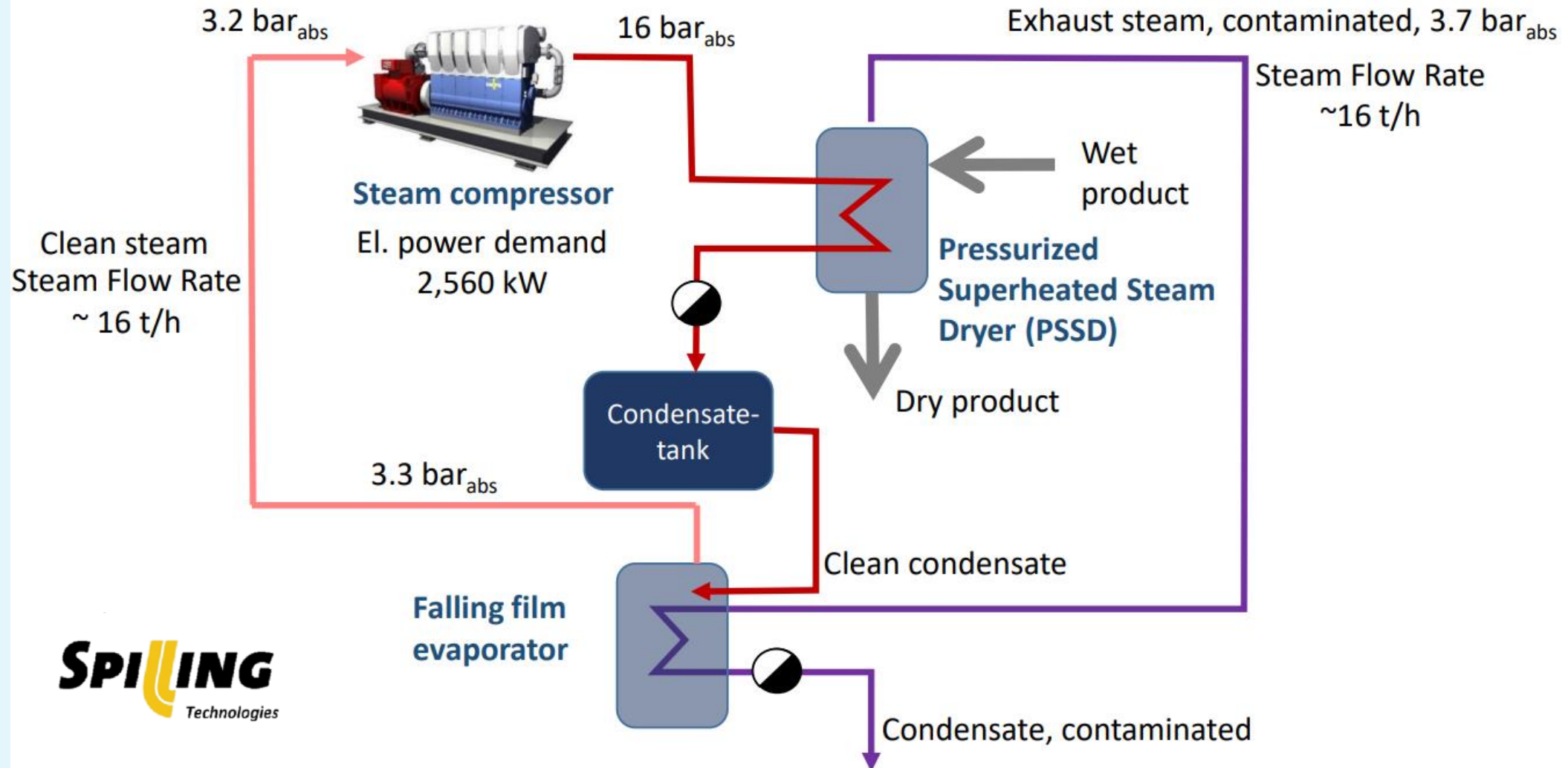



Open warmtepompen

Meertraps centrifugaal en axiaal compressoren



Piller

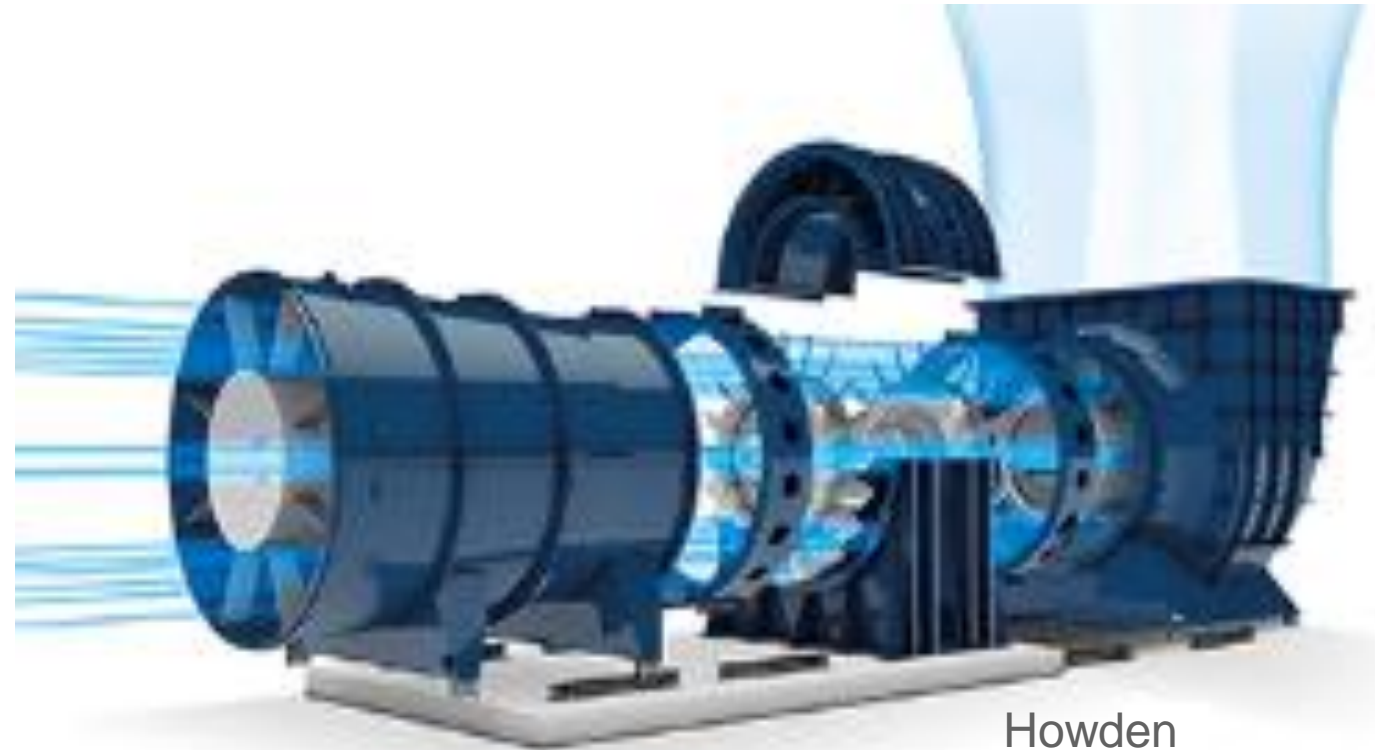

Howden



Conclusies

Geïntegreerde wamtepomp drogers

- Procesintegratie rond unitoperation aantrekkelijk : stekkerklaar
- Steam drying energetisch het best
 - Mogelijk ander product



BlueTerra

Energy Experts

blueterra.nl

